

STRUCTALL BUILDING SYSTEMS

EPS FOAM CORE WALL PANELS - METAL SKIN

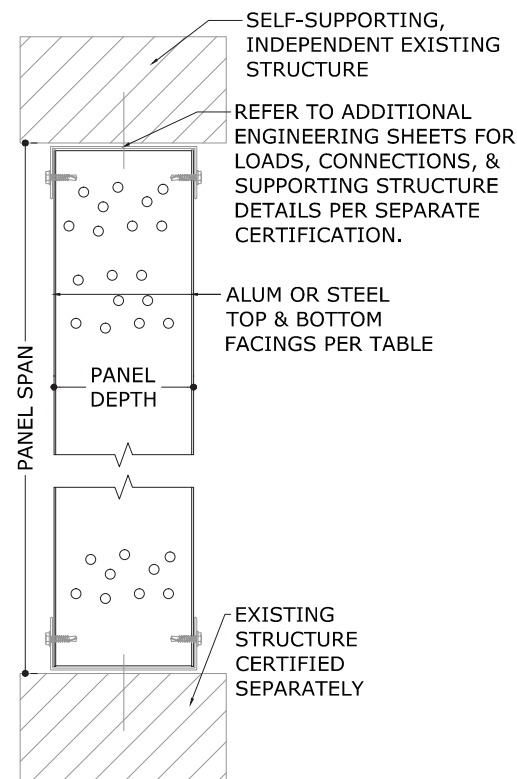

1 WALL PANEL SPAN
1 N.T.S. PLAN OR SECTION

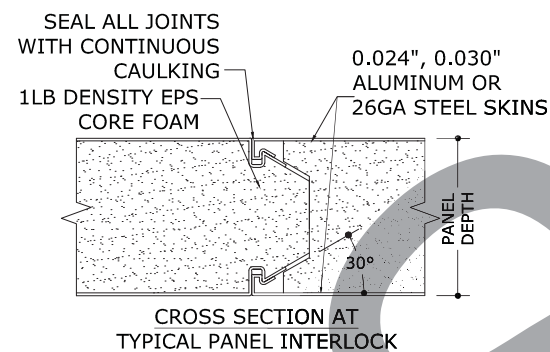

2 PANEL INTERLOCK DETAIL
1 N.T.S. DETAIL

MAXIMUM ALLOWABLE CLEAR SPAN TABLE:

Max Allowable Wall Load	Deflection Limit (L/...)	3\"/>							
		0.024\"/>	0.030\"/>	0.024\"/>	0.030\"/>	26ga Steel Skin	0.024\"/>	0.030\"/>	26ga Steel Skin
		1-LB EPS	1-LB EPS	1-LB EPS	1-LB EPS	1-LB EPS	1-LB EPS	1-LB EPS	1-LB EPS
+/- 10 psf	120	14'-10"	16'-0"	17'-6"	19'-9"	20'-3"	21'-9"	24'-0"	23'-0"
+/- 10 psf	240	11'-9"	15'-9"	13'-11"	15'-8"	16'-10"	17'-3"	19'-5"	20'-9"
+/- 15 psf	120	12'-12"	16'-0"	15'-4"	17'-3"	16'-6"	18'-1"	20'-2"	20'-5"
+/- 15 psf	240	10'-4"	13'-9"	12'-2"	13'-9"	14'-8"	15'-1"	16'-12"	18'-1"
+/- 20 psf	120	11'-9"	13'-11"	13'-11"	15'-3"	14'-4"	15'-8"	17'-6"	17'-8"
+/- 20 psf	240	9'-4"	12'-6"	11'-1"	12'-6"	13'-4"	13'-9"	15'-5"	16'-6"
+/- 25 psf	120	10'-11"	12'-5"	12'-9"	13'-8"	12'-10"	14'-0"	15'-8"	15'-10"
+/- 25 psf	240	8'-8"	11'-7"	10'-3"	11'-7"	12'-5"	12'-9"	14'-4"	15'-3"
+/- 30 psf	120	10'-0"	11'-4"	11'-8"	12'-6"	11'-8"	12'-9"	14'-3"	14'-5"
+/- 30 psf	240	8'-2"	10'-11"	9'-8"	10'-11"	11'-8"	11'-12"	13'-6"	14'-5"
+/- 35 psf	120	9'-3"	10'-6"	10'-9"	11'-7"	10'-10"	11'-10"	13'-3"	13'-4"
+/- 35 psf	240	7'-9"	10'-4"	9'-2"	10'-4"	10'-10"	11'-5"	12'-9"	13'-4"
+/- 39 psf	120	8'-10"	9'-11"	10'-3"	10'-11"	10'-3"	11'-3"	12'-6"	12'-8"
+/- 39 psf	240	7'-6"	9'-11"	8'-10"	9'-12"	10'-3"	10'-12"	12'-4"	12'-8"
+/- 45 psf	120	8'-2"	9'-3"	9'-6"	10'-2"	9'-6"	10'-5"	11'-8"	11'-9"
+/- 45 psf	240	7'-2"	9'-3"	8'-5"	9'-6"	9'-6"	10'-5"	11'-8"	11'-9"
+/- 50 psf	120			9'-0"	9'-8"	9'-1"	9'-11"	11'-1"	11'-2"
+/- 50 psf	240			8'-2"	9'-2"	9'-1"	9'-11"	11'-1"	11'-2"
+/- 55 psf	120			8'-7"	9'-3"	8'-7"	9'-5"	10'-7"	10'-8"
+/- 55 psf	240			7'-11"	8'-11"	8'-7"	9'-5"	10'-7"	10'-8"
+/- 60 psf	120			8'-3"	8'-10"	8'-3"	9'-0"	10'-1"	10'-2"
+/- 60 psf	240			7'-8"	8'-8"	8'-3"	9'-0"	10'-1"	10'-2"
+/- 65 psf	120			7'-10"	7'-10"	7'-11"	8'-8"	9'-8"	9'-10"
+/- 65 psf	240			7'-6"	7'-6"	7'-11"	8'-8"	9'-8"	9'-10"
+/- 70 psf	120			7'-3"	7'-3"	7'-8"	8'-4"	9'-4"	9'-5"
+/- 70 psf	240			7'-3"	7'-3"	7'-8"	8'-4"	9'-4"	9'-5"
+/- 78 psf	120					7'-3"	7'-11"	8'-10"	8'-11"
+/- 78 psf	240					7'-3"	7'-11"	8'-10"	8'-11"
+/- 80 psf	120							8'-9"	8'-10"
+/- 80 psf	240							8'-9"	8'-10"
+/- 85 psf	120							8'-6"	8'-7"
+/- 85 psf	240							8'-6"	8'-7"
+/- 90 psf	120							8'-3"	8'-4"
+/- 90 psf	240							8'-3"	8'-4"
+/- 95 psf	120							8'-0"	8'-1"
+/- 95 psf	240							8'-0"	8'-1"

DIRECTIVE FOR USE:

- DETERMINE TYPE OF ENCLOSURE TO BE COVERED (OPEN, SCREENED WALLS, OR FULLY ENCLOSED).
- VERIFY APPROPRIATE DESIGN LOAD WITH GOVERNING MUNICIPALITY AND BUILDING CODES IN EFFECT FOR THE PROJECT LOCATION USING FLORIDA BUILDING CODE AS APPLICABLE AS PROVIDED BY SEPARATE ENGINEERING, BY A LICENSED ENGINEER OR REGISTERED ARCHITECT. SEPARATE ENGINEERING MAY BE REQUIRED FOR ALTERNATE DESIGN LOADS.
- FIND ALLOWABLE COMPOSITE PANEL CLEAR SPAN IN TABLES FOR APPROPRIATE PANEL DEPTH, FACING THICKNESS, AND EPS CORE DENSITY SELECTED.
- INDICATES VALUES NOT VALID FOR USE.

DEFLECTION NOTES:

- USE L/240 FOR ALL EXTERIOR WALLS AND INTERIOR PARTITIONS WITH BRITTLE FINISHES.
- USE L/120 FOR ALL EXTERIOR WALLS AND INTERIOR PARTITIONS WITH FLEXIBLE FINISHES.
- LOCAL CODES MAY SUPERSEDE THE ABOVE BASE DEFLECTION CRITERIA FROM THE FLORIDA BUILDING CODE. CONTRACTOR TO VERIFY ALL LOCAL CODES WHICH MAY APPLY BEFORE USE OF THIS DESIGN.

MAXIMUM ALLOWABLE DESIGN PRESSURES:

AS NOTED IN CLEAR SPAN TABLE

DESIGN NOTES:

POSITIVE AND NEGATIVE DESIGN PRESSURES CALCULATED FOR USE WITH THIS SYSTEM SHALL BE DETERMINED BY OTHERS ON A JOB-SPECIFIC BASIS IN ACCORDANCE WITH THE GOVERNING CODE. SITE-SPECIFIC LOAD REQUIREMENTS FOR WIND LOAD, SNOW LOAD OR ANY LOAD COMBINATION SHALL BE DETERMINED IN ACCORDANCE WITH ASCE 7-10 AND THE FLORIDA BUILDING CODE (AS APPLICABLE) BY SEPARATE ENGINEERING CERTIFICATION AND SHALL BE LESS THAN OR EQUAL TO THE POSITIVE OR NEGATIVE DESIGN PRESSURE CAPACITY VALUES LISTED HEREIN FOR ANY ASSEMBLY AS SHOWN.

GENERAL NOTES:

- THIS SPECIFICATION HAS BEEN DESIGNED AND SHALL BE FABRICATED IN ACCORDANCE WITH THE REQUIREMENTS OF THE FLORIDA BUILDING CODE SIXTH EDITION (2017). CONTRACTOR SHALL INVESTIGATE AND CONFORM TO ALL LOCAL BUILDING CODE AMENDMENTS WHICH MAY APPLY. DESIGN CRITERIA BEYOND AS STATED HEREIN MAY REQUIRE ADDITIONAL SITE-SPECIFIC SEALED ENGINEERING. SEISMIC DESIGN HAS NOT BEEN CONSIDERED.
- COMPOSITE PANELS SHALL COMPLY WITH CHAPTER 7 SECTION 721, CHAPTER 8 SECTION 803, CLASS A INTERIOR FINISH, AND CHAPTER 26 SECTION 2603 OF THE FBC FIFTH EDITION.
- NO 33-1/3% INCREASE IN ALLOWABLE STRESS HAS BEEN USED IN THE DESIGN OF THIS SYSTEM.
- DESIGN PRESSURES AS NOTED HEREIN ARE BASED ON A MAXIMUM TESTED PRESSURE DIVIDED BY A 2.0 FACTOR OF SAFETY. WEIGHT OF THE PANELS HAS NOT BEEN INCLUDED, WALL PANELS SHALL BE INSTALLED PLUMB TO THE VERTICAL WITH NO SLOPING IN THE HORIZONTAL DIRECTION.
- THE ARCHITECT/ENGINEER OF RECORD FOR THE PROJECT SUPERSTRUCTURE WITH WHICH THIS DESIGN IS USED SHALL BE RESPONSIBLE FOR THE INTEGRITY OF ALL SUPPORTING SURFACES TO THIS DESIGN WHICH SHALL BE COORDINATED BY THE PERMITTING CONTRACTOR.
- SEPARATE 'SITE-SPECIFIC' SEALED ENGINEERING SHALL BE REQUIRED IN ORDER TO DEVIATE FROM LOADS, DEFLECTIONS, OR SPANS CONTAINED HEREIN. LINEAR INTERPOLATION OF THE ALLOWABLE SPAN TABLES LISTED HEREIN SHALL NOT BE PERMITTED. CONTACT THIS ENGINEER FOR ALTERNATE SPAN CALCULATIONS AS MAY BE REQUIRED.
- THE SYSTEM DETAILED HEREIN IS GENERIC AND DOES NOT PROVIDE INFORMATION FOR A SPECIFIC SITE. FOR SITE CONDITIONS DIFFERENT FROM THE CONDITIONS DETAILED HEREIN, A LICENSED ENGINEER OR REGISTERED ARCHITECT SHALL PREPARE SITE SPECIFIC DOCUMENTS FOR USE IN CONJUNCTION WITH THIS DOCUMENT.
- THE CONTRACTOR SHALL CAREFULLY CONSIDER POSSIBLE IMPOSING LOADS, INCLUDING BUT NOT LIMITED TO ANY CONCENTRATED LOADS WHICH MAY JUSTIFY GREATER DESIGN CRITERIA. THIS ADDITIONAL LOAD CRITERIA SHALL BE PROPERLY ANALYZED BY A LICENSED ENGINEER OR REGISTERED ARCHITECT.
- EPS CORE COMPOSITE PANELS SHALL BE CONSTRUCTED USING TYPE 3105-H254 ALUMINUM FACINGS OR ASTM A653, CS, TYPE B HOT DIP GALVANIZED G90 COATED STEEL FACINGS. EXPANDED POLYSTYRENE FOAM SHALL HAVE TYPICAL DENSITY OF 1.0 PCF. THE EPS FOAM SHALL BE ADHERED TO THE ALUMINUM FACING WITH MORAD M640 SERIES ADHESIVE (BY ROHM AND HAAS COMPANY). FABRICATION SHALL BE IN ACCORDANCE WITH APPROVED FABRICATION METHODS BY MANUFACTURER FOR ALL PANELS.
- THE CONTRACTOR IS RESPONSIBLE TO INSULATE ALL MEMBERS FROM DISSIMILAR MATERIALS TO PREVENT ELECTROLYSIS.
- ENGINEER SEAL AFFIXED HERE TO VALIDATES STRUCTURAL DESIGN AS SHOWN ONLY. USE OF THIS SPECIFICATION BY CONTRACTOR, ET AL. INDEMNIFIES & SAVES HARMLESS THIS ENGINEER FOR ALL COST & DAMAGES INCLUDING LEGAL FEES & APPELLATE FEES RESULTING FROM MATERIAL FABRICATION, SYSTEM ERECTION, & CONSTRUCTION PRACTICES BEYOND THAT WHICH IS CALLED FOR BY LOCAL, STATE, & FEDERAL CODES & FROM DEVIATIONS OF THIS PLAN.
- EXCEPT AS EXPRESSLY PROVIDED HEREIN, NO ADDITIONAL CERTIFICATIONS OR AFFIRMATIONS ARE INTENDED.
- ALTERATIONS, ADDITIONS, OR OTHER MARKINGS TO THIS DOCUMENT ARE NOT PERMITTED AND INVALIDATE THIS CERTIFICATION.

TABLE VALUE DERIVATIONS:

- PANEL PROPERTIES:
- PANEL STRUCTURAL PROPERTIES DERIVED FROM CERTIFIED TEST REPORTS Nos. TT-506027B, 506027C, 506027D, 509014A, 509014B BY TERRAPIN TESTING, ESP012351P-1, ESP012351P-2, ESP012351P-3, ESP012351P-3A, ESP012351P-4, ESP012351P-5, ESP012351P-6, EXP012351P-6A, ESP012351P-7, ESP012351P-8, ESP012351P-9, ESP012351P-9A BY ELEMENT MATERIALS TECHNOLOGY.
 - PANEL DEAD LOADS HAVE NOT BEEN FACTORED INTO CALCULATIONS FOR WALL PANEL PROPERTIES.

FRANK L. BENNARDO, P.E.
PE# 0046549

03/02/2018

IF CHECKED, CERTIFYING P.E. APPEARS BELOW
GORDON DIBATTISTO, P.E.
PE# 82328

VALID FOR 1 PERMIT ONLY U.N.O.

NOTICE: IF THIS SHEET DOES NOT CONTAIN AN ORIGINAL SIGNATURE & ENGINEER SEAL:

IF THERE IS A DIGITAL SIGNATURE ON SHEET 1, THIS SHEET IS PART OF A DIGITALLY SIGNED FILE, SHALL REMAIN IN DIGITAL FORMAT, & PRINTED COPIES OF THIS DOCUMENT ARE NOT CONSIDERED SIGNED AND SEALED. IF THERE IS NO DIGITAL SIGNATURE ON SHEET 1 OR THIS SHEET DOES NOT CONTAIN AN ENGINEER'S ORIGINAL SIGNATURE & SEAL, THIS SHEET IS A COPY/DRAFT.

ENGINEERING EXPRESS
CORPORATE OFFICE:
160 SW 12th AVE, SUITE 106
DEERFIELD BEACH, FL 33442
P: (954) 354-0660 F: (954) 354-0443
E: HELLO@ENGINEERINGEXPRESS.COM
ENGINEERINGEXPRESS.COM
CERT OF AUTH #9885

STRUCTALL BUILDING SYSTEMS
350 BURBANK ROAD
OLDSMAR, FL 34677
PH: (813) 855-2627

EPS FOAM CORE WALL PANELS - METAL SKIN
STRUCTURAL SPAN TABLES

DRWN	CHKD	DATE
JAC	FLB	01/25/18

REMARKS
INIT ISSUE

THIS DOCUMENT IS THE PROPERTY OF ENGINEERING EXPRESS AND SHALL NOT BE REPRODUCED IN WHOLE OR PART WITHOUT WRITTEN CONSENT OF ENGINEERING EXPRESS. ALTERATIONS, ADDITIONS, OR OTHER MARKINGS TO THIS DOCUMENT ARE NOT PERMITTED AND INVALIDATE OUR CERTIFICATION.

COPYRIGHT ENGINEERING EXPRESS®

18-5569

SCALE: NTS UNLESS NOTED

1 of 1